

4 In 1 Compact Fiber Laser

Cut, Weld, Clean & Engrave

M2 Ultra

Bed Size: 1300x900mm Bed (600x600mm available)

Power: 800W/1200W

FROM

\$25,955+GST



The 4-in-1 machine is our newest model, combining the 3-in-1 Fiber welder technology with an enclosed CNC bed, allows you to weld cut and clean metal materials by hand, then attach the Fiber into the enclosed CNC machine for precision sheet metal cutting. Perfect for R&D prototyping, educational facilities and small makers.



CNC Laser Cutting



Laser Welding

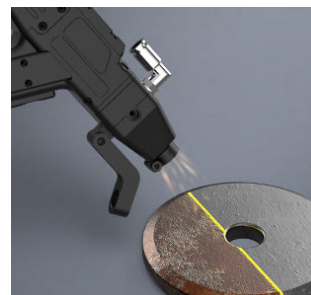

Laser Cleaning

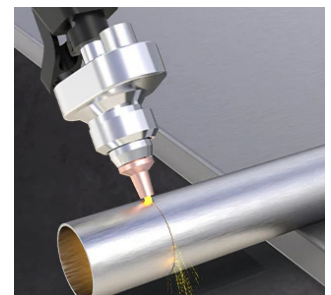

Hand-Held Cutting

Features:

- 1300x900mm bed size
- Class 1 enclosed CNC machine body
- Class 4 portable welding/cleaning/handcutting
- Detach the fiber laser head from the enclosed CNC machine and it becomes a portable welding/cleaning and hand cutting machine
- Air cooled fiber source
- Au3tec controller system and software
- CNC Positioning and re-positioning accuracy 0.03mm
- Automatic crash detection, Industrial nesting, fly-cutting as standard
- Built-in extraction fan
- Leadshine servo motor drive
- Under table high pressure exhaust system
- When disconnected the source becomes a small portable air-cooled machine with light weight gun
- Up to 5x faster welding than Tig
- Fast 30 second interchange between CNC and hand head unit
- Fast 15 second nozzle exchange, to quickly swap between welding/cutting and hand cleaning
- Wire feeder included, welding with or without wire

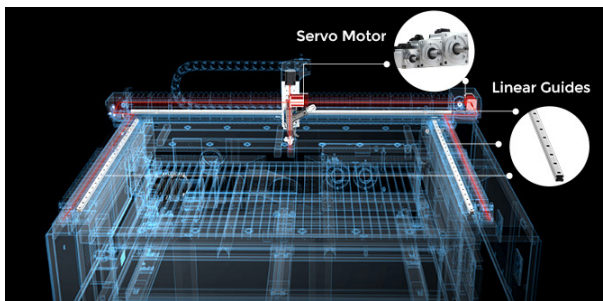
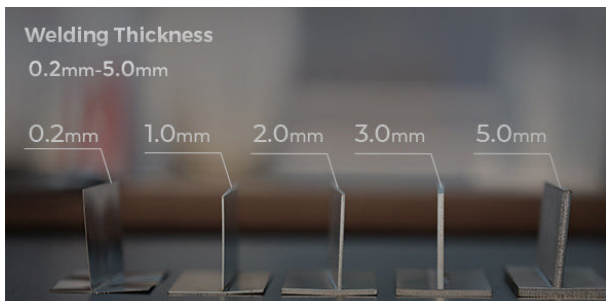
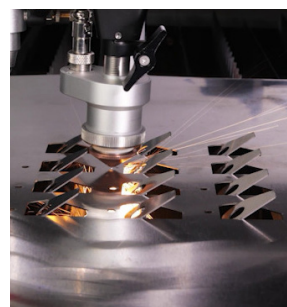
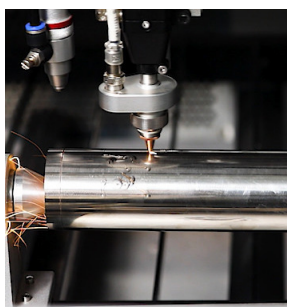
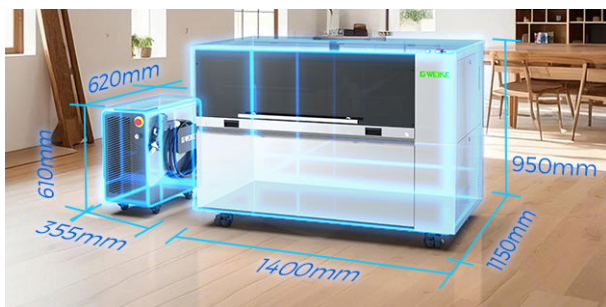

The new 4-in-1 machine is compact, taking up less space in your studio, workshop or factory. Have the confidence that you will be precision cutting metal, with automatic crash detection for reliable cutting every time. Take your designed to the third-dimension welding brackets, structures and sculptures. Quickly interchange between the hand-held welding/cleaning/hand cutting nozzles in 15 seconds, mount the head within the CNC enclosure withing 30 seconds for Metal CNC cutting.

Technical Parameters	Specifications
Fiber Laser Power	Base & Max model: 800W / Pro & Ultra: 1200W
Safety Class	Class 1 enclosure for CNC cutting, Class 4 as handheld welding/cleaning/hand cutting unit NOTE: For Educational set up, this machine should be used for CNC function only
Cutting Area	Base & Pro model = 600 x 300mm Max & Ultra model = 1300 x 900mm
Laser Head Type	Au3tec manual focusing head
Cooling Type	Air cooled Fiber source
Moving Speed	X-axis = 800mm/s, Y-axis = 500mm/s
Acceleration	0.8G
Laser Output Control	0-100% set by software
Drive Method	Leadshine servo driver with high precision belt drive
Positioning Accuracy	±0.05 mm
Re-positioning Accuracy	±0.03 mm
Minimum Line Width	0.1mm
Controlling Software	Au3tec software and control system, including nesting, edge seeking and automatic crash Protection, fly-cutting etc, import DXF created by any design or CAD software
Power Supply	Machine: 800W = 1x10A + 1x20A 230V/50Hz 1200W = 1x10A + 1x25A 230V/50Hz
Gas Regulation	Software controlled electronic low- pressure O2 regulator (for fine adjustment at low pressure)
Gas Connection	O2 (mild steel and copper cutting) Min 99.7% purity – 10m3/h maximum flow rate – 10bar max pressure N2 (Stainless, Aluminium, Brass and thin Mild steel cutting) Min 99.9% purity – 40m3/h maximum flow rate – 24bar max pressure Compressed air (Stainless, Aluminium, Brass and thin Mild steel cutting) SEE OUR 15DHY-15B or 20DHY-20Bar COMPRESSOR OPTIONS
Working Environment	Temperature 20-40C, Humidity 5-95% (No Condensate Water)
Options	Honeycomb table, air filtration, rotary
Machine Footprint	Base & Pro = 1400*795*950mm CNC machine, 355*610*620mm welding unit Max & Ultra = 2185*1780*1100mm CNC machine, 355*610*620mm welding unit
Weight	Base & Pro = 250kg Max & Ultra = 750kg